

Chapter H

LV switchgear: functions & selection

Contents

1	The basic functions of LV switchgear	H2
	1.1 Electrical protection	H2
	1.2 Isolation	H3
	1.3 Switchgear control	H4
2	The switchgear	H5
	2.1 Elementary switching devices	H5
	2.2 Combined switchgear elements	H9
3	Choice of switchgear	H10
	3.1 Tabulated functional capabilities	H10
	3.2 Switchgear selection	H10
4	Circuit-breaker	H11
	4.1 Standards and description	H11
	4.2 Fundamental characteristics of a circuit-breaker	H13
	4.3 Other characteristics of a circuit-breaker	H15
	4.4 Selection of a circuit-breaker	H18
	4.5 Coordination between circuit-breakers	H22
	4.6 Discrimination MV/LV in a consumer's substation	H28

H1

1 The basic functions of LV switchgear

The role of switchgear is:

- Electrical protection
- Safe isolation from live parts
- Local or remote switching

National and international standards define the manner in which electric circuits of LV installations must be realized, and the capabilities and limitations of the various switching devices which are collectively referred to as switchgear.

The main functions of switchgear are:

- Electrical protection
- Electrical isolation of sections of an installation
- Local or remote switching

These functions are summarized below in **Figure H1**.

Electrical protection at low voltage is (apart from fuses) normally incorporated in circuit-breakers, in the form of thermal-magnetic devices and/or residual-current-operated tripping devices (less-commonly, residual voltage- operated devices - acceptable to, but not recommended by IEC).

In addition to those functions shown in Figure H1, other functions, namely:

- Over-voltage protection
- Under-voltage protection

are provided by specific devices (lightning and various other types of voltage-surge arrester, relays associated with contactors, remotely controlled circuit-breakers, and with combined circuit-breaker/isolators... and so on)

Electrical protection against	Isolation	Control
<ul style="list-style-type: none"> ■ Overload currents ■ Short-circuit currents ■ Insulation failure 	<ul style="list-style-type: none"> ■ Isolation clearly indicated by an authorized fail-proof mechanical indicator ■ A gap or interposed insulating barrier between the open contacts, clearly visible 	<ul style="list-style-type: none"> ■ Functional switching ■ Emergency switching ■ Emergency stopping ■ Switching off for mechanical maintenance

Fig. H1 : Basic functions of LV switchgear

H2

Electrical protection assures:

- Protection of circuit elements against the thermal and mechanical stresses of short-circuit currents
- Protection of persons in the event of insulation failure
- Protection of appliances and apparatus being supplied (e.g. motors, etc.)

1.1 Electrical protection

The aim is to avoid or to limit the destructive or dangerous consequences of excessive (short-circuit) currents, or those due to overloading and insulation failure, and to separate the defective circuit from the rest of the installation.

A distinction is made between the protection of:

- The elements of the installation (cables, wires, switchgear...)
- Persons and animals
- Equipment and appliances supplied from the installation

The protection of circuits

- Against overload; a condition of excessive current being drawn from a healthy (unfaulted) installation
- Against short-circuit currents due to complete failure of insulation between conductors of different phases or (in TN systems) between a phase and neutral (or PE) conductor

Protection in these cases is provided either by fuses or circuit-breaker, in the distribution board at the origin of the final circuit (i.e. the circuit to which the load is connected). Certain derogations to this rule are authorized in some national standards, as noted in chapter H1 sub-clause 1.4.

The protection of persons

- Against insulation failures. According to the system of earthing for the installation (TN, TT or IT) the protection will be provided by fuses or circuit-breakers, residual current devices, and/or permanent monitoring of the insulation resistance of the installation to earth

The protection of electric motors

- Against overheating, due, for example, to long term overloading, stalled rotor, single-phasing, etc. Thermal relays, specially designed to match the particular characteristics of motors are used. Such relays may, if required, also protect the motor-circuit cable against overload. Short-circuit protection is provided either by type aM fuses or by a circuit-breaker from which the thermal (overload) protective element has been removed, or otherwise made inoperative.

1 The basic functions of LV switchgear

A state of isolation clearly indicated by an approved "fail-proof" indicator, or the visible separation of contacts, are both deemed to satisfy the national standards of many countries

1.2 Isolation

The aim of isolation is to separate a circuit or apparatus (such as a motor, etc.) from the remainder of a system which is energized, in order that personnel may carry out work on the isolated part in perfect safety.

In principle, all circuits of an LV installation shall have means to be isolated. In practice, in order to maintain an optimum continuity of service, it is preferred to provide a means of isolation at the origin of each circuit.

An isolating device must fulfil the following requirements:

- All poles of a circuit, including the neutral (except where the neutral is a PEN conductor) must open⁽¹⁾
- It must be provided with a locking system in open position with a key (e.g. by means of a padlock) in order to avoid an unauthorized reclosure by inadvertence
- It must comply with a recognized national or international standard (e.g. IEC 60947-3) concerning clearance between contacts, creepage distances, overvoltage withstand capability, etc.:

Other requirements apply:

- Verification that the contacts of the isolating device are, in fact, open.

The verification may be:

- Either visual, where the device is suitably designed to allow the contacts to be seen (some national standards impose this condition for an isolating device located at the origin of a LV installation supplied directly from a MV/LV transformer)
- Or mechanical, by means of an indicator solidly welded to the operating shaft of the device. In this case the construction of the device must be such that, in the eventuality that the contacts become welded together in the closed position, the indicator cannot possibly indicate that it is in the open position

- Leakage currents. With the isolating device open, leakage currents between the open contacts of each phase must not exceed:

- 0.5 mA for a new device
- 6.0 mA at the end of its useful life

- Voltage-surge withstand capability, across open contacts. The isolating device, when open must withstand a 1.2/50 μ s impulse, having a peak value of 6, 8 or 12 kV according to its service voltage, as shown in **Figure H2**. The device must satisfy these conditions for altitudes up to 2,000 metres. Correction factors are given in IEC 60664-1 for altitudes greater than 2,000 metres.

Consequently, if tests are carried out at sea level, the test values must be increased by 23% to take into account the effect of altitude. See standard IEC 60947.

Service (nominal voltage (V))	Impulse withstand peak voltage category (for 2,000 metres) (kV)	
	III	IV
230/400	4	6
400/690	6	8
690/1,000	8	12

Fig. H2 : Peak value of impulse voltage according to normal service voltage of test specimen. The degrees III and IV are degrees of pollution defined in IEC 60664-1

(1) the concurrent opening of all live conductors, while not always obligatory, is however, strongly recommended (for reasons of greater safety and facility of operation). The neutral contact opens after the phase contacts, and closes before them (IEC 60947-1).

1 The basic functions of LV switchgear

Switchgear-control functions allow system operating personnel to modify a loaded system at any moment, according to requirements, and include:

- Functional control (routine switching, etc.)
- Emergency switching
- Maintenance operations on the power system

1.3 Switchgear control

In broad terms “control” signifies any facility for safely modifying a load-carrying power system at all levels of an installation. The operation of switchgear is an important part of power-system control.

Functional control

This control relates to all switching operations in normal service conditions for energizing or de-energizing a part of a system or installation, or an individual piece of equipment, item of plant, etc.

Switchgear intended for such duty must be installed at least:

- At the origin of any installation
- At the final load circuit or circuits (one switch may control several loads)

Marking (of the circuits being controlled) must be clear and unambiguous.

In order to provide the maximum flexibility and continuity of operation, particularly where the switching device also constitutes the protection (e.g. a circuit-breaker or switch-fuse) it is preferable to include a switch at each level of distribution, i.e. on each outgoing way of all distribution and subdistribution boards.

The manoeuvre may be:

- Either manual (by means of an operating lever on the switch) or
- Electric, by push-button on the switch or at a remote location (load-shedding and reconnection, for example)

These switches operate instantaneously (i.e. with no deliberate delay), and those that provide protection are invariably omni-polar⁽¹⁾.

The main circuit-breaker for the entire installation, as well as any circuit-breakers used for change-over (from one source to another) must be omni-polar units.

Emergency switching - emergency stop

An emergency switching is intended to de-energize a live circuit which is, or could become, dangerous (electric shock or fire).

An emergency stop is intended to halt a movement which has become dangerous.

In the two cases:

- The emergency control device or its means of operation (local or at remote location(s)) such as a large red mushroom-headed emergency-stop pushbutton must be recognizable and readily accessible, in proximity to any position at which danger could arise or be seen
- A single action must result in a complete switching-off of all live conductors ⁽²⁾ ⁽³⁾
- A “break glass” emergency switching initiation device is authorized, but in unmanned installations the re-energizing of the circuit can only be achieved by means of a key held by an authorized person

It should be noted that in certain cases, an emergency system of braking, may require that the auxiliary supply to the braking-system circuits be maintained until final stoppage of the machinery.

Switching-off for mechanical maintenance work

This operation assures the stopping of a machine and its impossibility to be inadvertently restarted while mechanical maintenance work is being carried out on the driven machinery. The shutdown is generally carried out at the functional switching device, with the use of a suitable safety lock and warning notice at the switch mechanism.

(1) One break in each phase and (where appropriate) one break in the neutral.

(2) Taking into account stalled motors.

(3) In a TN schema the PEN conductor must never be opened, since it functions as a protective earthing wire as well as the system neutral conductor.

2.1 Elementary switching devices

Disconnecter (or isolator) (see Fig. H5)

This switch is a manually-operated, lockable, two-position device (open/closed) which provides safe isolation of a circuit when locked in the open position. Its characteristics are defined in IEC 60947-3. A disconnecter is not designed to make or to break current⁽¹⁾ and no rated values for these functions are given in standards. It must, however, be capable of withstanding the passage of short-circuit currents and is assigned a rated short-time withstand capability, generally for 1 second, unless otherwise agreed between user and manufacturer. This capability is normally more than adequate for longer periods of (lower-valued) operational overcurrents, such as those of motor-starting. Standardized mechanical-endurance, overvoltage, and leakage-current tests, must also be satisfied.

Load-breaking switch (see Fig. H6)

This control switch is generally operated manually (but is sometimes provided with electrical tripping for operator convenience) and is a non-automatic two-position device (open/closed).

It is used to close and open loaded circuits under normal unfaulted circuit conditions. It does not consequently, provide any protection for the circuit it controls.

IEC standard 60947-3 defines:

- The frequency of switch operation (600 close/open cycles per hour maximum)
- Mechanical and electrical endurance (generally less than that of a contactor)

Current making and breaking ratings for normal and infrequent situations
When closing a switch to energize a circuit there is always the possibility that an unsuspected short-circuit exists on the circuit. For this reason, load-break switches are assigned a fault-current making rating, i.e. successful closure against the electrodynamic forces of short-circuit current is assured. Such switches are commonly referred to as "fault-make load-break" switches. Upstream protective devices are relied upon to clear the short-circuit fault

Category AC-23 includes occasional switching of individual motors. The switching of capacitors or of tungsten filament lamps shall be subject to agreement between manufacturer and user.

The utilization categories referred to in **Figure H7** do not apply to an equipment normally used to start, accelerate and/or stop individual motors.

Example

A 100 A load-break switch of category AC-23 (inductive load) must be able:

- To make a current of 10 In (= 1,000 A) at a power factor of 0.35 lagging
- To break a current of 8 In (= 800 A) at a power factor of 0.45 lagging
- To withstand short duration short-circuit currents when closed



Fig. H5 : Symbol for a disconnecter (or isolator)

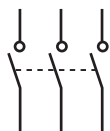

Fig. H6 : Symbol for a load-break switch

Utilization category		Typical applications	Cos φ	Making current x In	Breaking current x In
Frequent operations	Infrequent operations				
AC-20A	AC-20B	Connecting and disconnecting under no-load conditions	-	-	-
AC-21A	AC-21B	Switching of resistive loads including moderate overloads	0.95	1.5	1.5
AC-22A	AC-22B	Switching of mixed resistive and inductive loads, including moderate overloads	0.65	3	3
AC-23A	AC-23B	Switching of motor loads or other highly inductive loads	0.45 for I ≤ 100 A 0.35 for I > 100 A	10	8

Fig. H7 : Utilization categories of LV AC switches according to IEC 60947-3

(1) i.e. a LV disconnecter is essentially a dead system switching device to be operated with no voltage on either side of it, particularly when closing, because of the possibility of an unsuspected short-circuit on the downstream side. Interlocking with an upstream switch or circuit-breaker is frequently used.

H6

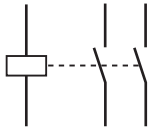

Fig. H8 : Symbol for a bistable remote control switch

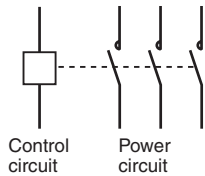

Fig. H9 : Symbol for a contactor

Two classes of LV cartridge fuse are very widely used:

- For domestic and similar installations type gG
- For industrial installations type gG, gM or aM



Fig. H10 : Symbol for fuses

Remote control switch (see Fig. H8)

This device is extensively used in the control of lighting circuits where the depression of a pushbutton (at a remote control position) will open an already-closed switch or close an opened switch in a bistable sequence.

Typical applications are:

- Two-way switching on stairways of large buildings
- Stage-lighting schemes
- Factory illumination, etc.

Auxiliary devices are available to provide:

- Remote indication of its state at any instant
- Time-delay functions
- Maintained-contact features

Contactor (see Fig. H9)

The contactor is a solenoid-operated switching device which is generally held closed by (a reduced) current through the closing solenoid (although various mechanically-latched types exist for specific duties). Contactors are designed to carry out numerous close/open cycles and are commonly controlled remotely by on-off pushbuttons. The large number of repetitive operating cycles is standardized in table VIII of IEC 60947-4-1 by:

- The operating duration: 8 hours; uninterrupted; intermittent; temporary of 3, 10, 30, 60 and 90 minutes
- Utilization category: for example, a contactor of category AC3 can be used for the starting and stopping of a cage motor
- The start-stop cycles (1 to 1,200 cycles per hour)
- Mechanical endurance (number of off-load manoeuvres)
- Electrical endurance (number of on-load manoeuvres)
- A rated current making and breaking performance according to the category of utilization concerned

Example:

A 150 A contactor of category AC3 must have a minimum current-breaking capability of $8 I_n$ (= 1,200 A) and a minimum current-making rating of $10 I_n$ (= 1,500 A) at a power factor (lagging) of 0.35.

Discontactor⁽¹⁾

A contactor equipped with a thermal-type relay for protection against overloading defines a "discontactor". Discontactors are used extensively for remote push-button control of lighting circuits, etc., and may also be considered as an essential element in a motor controller, as noted in sub-clause 2.2. "combined switchgear elements". The discontactor is not the equivalent of a circuit-breaker, since its short-circuit current breaking capability is limited to 8 or 10 I_n . For short-circuit protection therefore, it is necessary to include either fuses or a circuit-breaker in series with, and upstream of, the discontactor contacts.

Fuses (see Fig. H10)

The first letter indicates the breaking range:

- "g" fuse-links (full-range breaking-capacity fuse-link)
- "a" fuse-links (partial-range breaking-capacity fuse-link)

The second letter indicates the utilization category; this letter defines with accuracy the time-current characteristics, conventional times and currents, gates.

For example

- "gG" indicates fuse-links with a full-range breaking capacity for general application
- "gM" indicates fuse-links with a full-range breaking capacity for the protection of motor circuits
- "aM" indicates fuse-links with a partial range breaking capacity for the protection of motor circuits

Fuses exist with and without "fuse-blown" mechanical indicators. Fuses break a circuit by controlled melting of the fuse element when a current exceeds a given value for a corresponding period of time; the current/time relationship being presented in the form of a performance curve for each type of fuse. Standards define two classes of fuse:

- Those intended for domestic installations, manufactured in the form of a cartridge for rated currents up to 100 A and designated type gG in IEC 60269-1 and 3
- Those for industrial use, with cartridge types designated gG (general use); and gM and aM (for motor-circuits) in IEC 60269-1 and 2

(1) This term is not defined in IEC publications but is commonly used in some countries.

The main differences between domestic and industrial fuses are the nominal voltage and current levels (which require much larger physical dimensions) and their fault-current breaking capabilities. Type gG fuse-links are often used for the protection of motor circuits, which is possible when their characteristics are capable of withstanding the motor-starting current without deterioration.

A more recent development has been the adoption by the IEC of a fuse-type gM for motor protection, designed to cover starting, and short-circuit conditions. This type of fuse is more popular in some countries than in others, but at the present time the aM fuse in combination with a thermal overload relay is more-widely used. A gM fuse-link, which has a dual rating is characterized by two current values. The first value I_n denotes both the rated current of the fuse-link and the rated current of the fuseholder; the second value I_{ch} denotes the time-current characteristic of the fuse-link as defined by the gates in Tables II, III and VI of IEC 60269-1.

These two ratings are separated by a letter which defines the applications.

For example: $I_n M I_{ch}$ denotes a fuse intended to be used for protection of motor circuits and having the characteristic G. The first value I_n corresponds to the maximum continuous current for the whole fuse and the second value I_{ch} corresponds to the G characteristic of the fuse link. For further details see note at the end of sub-clause 2.1.

An aM fuse-link is characterized by one current value I_n and time-current characteristic as shown in Figure H14 next page.

Important: Some national standards use a gl (industrial) type fuse, similar in all main essentials to type gG fuses.

Type gl fuses should never be used, however, in domestic and similar installations.

gM fuses require a separate overload relay, as described in the note at the end of sub-clause 2.1.

Fusing zones - conventional currents

The conditions of fusing (melting) of a fuse are defined by standards, according to their class.

Class gG fuses

These fuses provide protection against overloads and short-circuits.

Conventional non-fusing and fusing currents are standardized, as shown in **Figure H12** and in **Figure H13**.

■ The conventional non-fusing current I_{nf} is the value of current that the fusible element can carry for a specified time without melting.

Example: A 32 A fuse carrying a current of $1.25 I_n$ (i.e. 40 A) must not melt in less than one hour (table H13)

■ The conventional fusing current I_f (= I_2 in Fig. H12) is the value of current which will cause melting of the fusible element before the expiration of the specified time.

Example: A 32 A fuse carrying a current of $1.6 I_n$ (i.e. 52.1 A) must melt in one hour or less

IEC 60269-1 standardized tests require that a fuse-operating characteristic lies between the two limiting curves (shown in Figure H12) for the particular fuse under test. This means that two fuses which satisfy the test can have significantly different operating times at low levels of overloading.

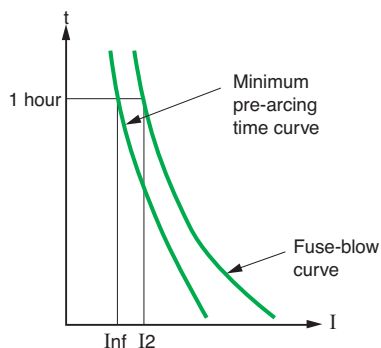

Fig. H12 : Zones of fusing and non-fusing for gG and gM fuses

Rated current ⁽¹⁾ I_n (A)	Conventional non-fusing current I_{nf}	Conventional fusing current I_2	Conventional time (h)
$I_n \leq 4$ A	$1.5 I_n$	$2.1 I_n$	1
$4 < I_n < 16$ A	$1.5 I_n$	$1.9 I_n$	1
$16 < I_n \leq 63$ A	$1.25 I_n$	$1.6 I_n$	1
$63 < I_n \leq 160$ A	$1.25 I_n$	$1.6 I_n$	2
$160 < I_n \leq 400$ A	$1.25 I_n$	$1.6 I_n$	3
$400 < I_n$	$1.25 I_n$	$1.6 I_n$	4

Fig. H13 : Zones of fusing and non-fusing for LV types gG and gM class fuses (IEC 60269-1 and 60269-2-1)

(1) I_{ch} for gM fuses

Class aM fuses protect against short-circuit currents only, and must always be associated with another device which protects against overload

- The two examples given above for a 32 A fuse, together with the foregoing notes on standard test requirements, explain why these fuses have a poor performance in the low overload range
 - It is therefore necessary to install a cable larger in ampacity than that normally required for a circuit, in order to avoid the consequences of possible long term overloading (60% overload for up to one hour in the worst case)
- By way of comparison, a circuit-breaker of similar current rating:
- Which passes 1.05 I_n must not trip in less than one hour; and
 - When passing 1.25 I_n it must trip in one hour, or less (25% overload for up to one hour in the worst case)

Class aM (motor) fuses

These fuses afford protection against short-circuit currents only and must necessarily be associated with other switchgear (such as discontactors or circuit-breakers) in order to ensure overload protection $< 4 I_n$. They are not therefore autonomous. Since aM fuses are not intended to protect against low values of overload current, no levels of conventional non-fusing and fusing currents are fixed. The characteristic curves for testing these fuses are given for values of fault current exceeding approximately $4 I_n$ (see Fig. H14), and fuses tested to IEC 60269 must give operating curves which fall within the shaded area.

Note: the small “arrowheads” in the diagram indicate the current/time “gate” values for the different fuses to be tested (IEC 60269).

Rated short-circuit breaking currents

A characteristic of modern cartridge fuses is that, owing to the rapidity of fusion in the case of high short-circuit current levels⁽¹⁾, a current cut-off begins before the occurrence of the first major peak, so that the fault current never reaches its prospective peak value (see Fig. H15).

This limitation of current reduces significantly the thermal and dynamic stresses which would otherwise occur, thereby minimizing danger and damage at the fault position. The rated short-circuit breaking current of the fuse is therefore based on the rms value of the AC component of the prospective fault current.

No short-circuit current-making rating is assigned to fuses.

Reminder

Short-circuit currents initially contain DC components, the magnitude and duration of which depend on the X_L/R ratio of the fault current loop.

Close to the source (MV/LV transformer) the relationship I_{peak} / I_{rms} (of AC component) immediately following the instant of fault, can be as high as 2.5 (standardized by IEC, and shown in Figure H16 next page).

At lower levels of distribution in an installation, as previously noted, X_L is small compared with R and so for final circuits $I_{peak} / I_{rms} \sim 1.41$, a condition which corresponds with Figure H15.

The peak-current-limitation effect occurs only when the prospective rms AC component of fault current attains a certain level. For example, in the Figure H16 graph, the 100 A fuse will begin to cut off the peak at a prospective fault current (rms) of 2 kA (a). The same fuse for a condition of 20 kA rms prospective current will limit the peak current to 10 kA (b). Without a current-limiting fuse the peak current could attain 50 kA (c) in this particular case. As already mentioned, at lower distribution levels in an installation, R greatly predominates X_L , and fault levels are generally low. This means that the level of fault current may not attain values high enough to cause peak current limitation. On the other hand, the DC transients (in this case) have an insignificant effect on the magnitude of the current peak, as previously mentioned.

Note: On gM fuse ratings

A gM type fuse is essentially a gG fuse, the fusible element of which corresponds to the current value I_{ch} (ch = characteristic) which may be, for example, 63 A. This is the IEC testing value, so that its time/ current characteristic is identical to that of a 63 A gG fuse.

This value (63 A) is selected to withstand the high starting currents of a motor, the steady state operating current (I_n) of which may be in the 10-20 A range. This means that a physically smaller fuse barrel and metallic parts can be used, since the heat dissipation required in normal service is related to the lower figures (10-20 A). A standard gM fuse, suitable for this situation would be designated 32M63 (i.e. $I_n M I_{ch}$).

The first current rating I_n concerns the steady-load thermal performance of the fuselink, while the second current rating (I_{ch}) relates to its (short-time) starting-current performance. It is evident that, although suitable for short-circuit protection,

H8

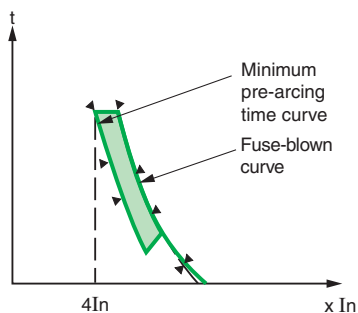
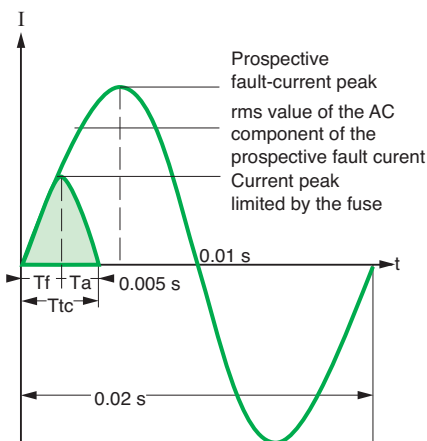

Fig. H14 : Standardized zones of fusing for type aM fuses (all current ratings)



Tf: Fuse pre-arc fusing time
 Ta: Arcing time
 Ttc: Total fault-clearance time

Fig. H15 : Current limitation by a fuse

(1) For currents exceeding a certain level, depending on the fuse nominal current rating, as shown below in Figure H16.

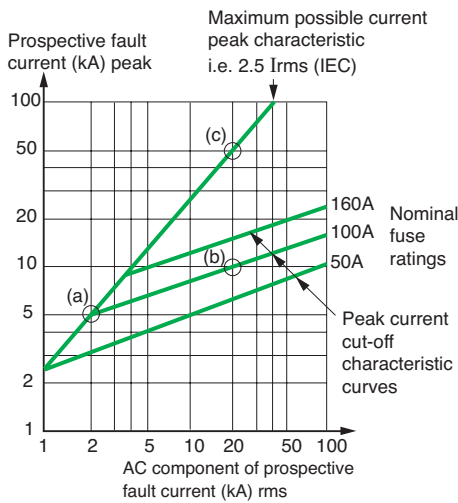

Fig. H16 : Limited peak current versus prospective rms values of the AC component of fault current for LV fuses

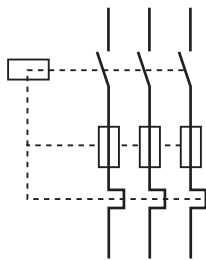

Fig. H17 : Symbol for an automatic tripping switch-fuse

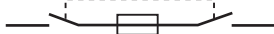

Fig. H18 : Symbol for a non-automatic fuse-switch

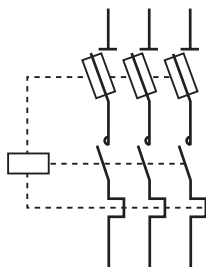

Fig. H20 : Symbol for a fuse disconnect + disconnector

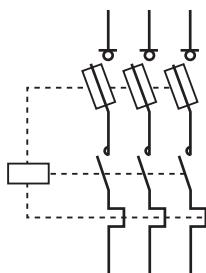

Fig. H21 : Symbol for a fuse-switch disconnect + disconnector

overload protection for the motor is not provided by the fuse, and so a separate thermal-type relay is always necessary when using gM fuses. The only advantage offered by gM fuses, therefore, when compared with aM fuses, are reduced physical dimensions and slightly lower cost.

2.2 Combined switchgear elements

Single units of switchgear do not, in general, fulfil all the requirements of the three basic functions, viz: Protection, control and isolation.

Where the installation of a circuit-breaker is not appropriate (notably where the switching rate is high, over extended periods) combinations of units specifically designed for such a performance are employed. The most commonly-used combinations are described below.

Switch and fuse combinations

Two cases are distinguished:

- The type in which the operation of one (or more) fuse(s) causes the switch to open. This is achieved by the use of fuses fitted with striker pins, and a system of switch tripping springs and toggle mechanisms (see Fig. H17)
- The type in which a non-automatic switch is associated with a set of fuses in a common enclosure.

In some countries, and in IEC 60947-3, the terms “switch-fuse” and “fuse-switch” have specific meanings, viz:

- A switch-fuse comprises a switch (generally 2 breaks per pole) on the upstream side of three fixed fuse-bases, into which the fuse carriers are inserted (see Fig. H18)
- A fuse-switch consists of three switch blades each constituting a double-break per phase.

These blades are not continuous throughout their length, but each has a gap in the centre which is bridged by the fuse cartridge. Some designs have only a single break per phase, as shown in Figure H19.

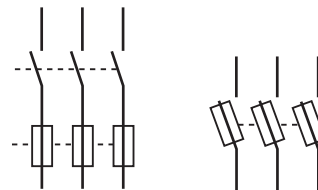

Fig. H19 : Symbol for a non-automatic switch-fuse

The current range for these devices is limited to 100 A maximum at 400 V 3-phase, while their principal use is in domestic and similar installations. To avoid confusion between the first group (i.e. automatic tripping) and the second group, the term “switch-fuse” should be qualified by the adjectives “automatic” or “non-automatic”.

Fuse – disconnect + disconnector

Fuse - switch-disconnector + disconnector

As previously mentioned, a disconnector does not provide protection against short-circuit faults. It is necessary, therefore, to add fuses (generally of type aM) to perform this function. The combination is used mainly for motor control circuits, where the disconnector or switch-disconnector allows safe operations such as:

- The changing of fuse links (with the circuit isolated)
- Work on the circuit downstream of the disconnector (risk of remote closure of the disconnector)

The fuse-disconnector must be interlocked with the disconnector such that no opening or closing manoeuvre of the fuse disconnector is possible unless the disconnector is open (Figure H20), since the fuse disconnector has no load-switching capability.

A fuse-switch-disconnector (evidently) requires no interlocking (Figure H21).

The switch must be of class AC22 or AC23 if the circuit supplies a motor.

Circuit-breaker + contactor

Circuit-breaker + disconnector

These combinations are used in remotely controlled distribution systems in which the rate of switching is high, or for control and protection of a circuit supplying motors.

3 Choice of switchgear

3.1 Tabulated functional capabilities

After having studied the basic functions of LV switchgear (clause 1, Figure H1) and the different components of switchgear (clause 2), **Figure H22** summarizes the capabilities of the various components to perform the basic functions.

Switchgear item	Isolation	Control				Electrical protection		
		Functional	Emergency switching	Emergency stop (mechanical)	Switching for mechanical maintenance	Overload	Short-circuit	Electric shock
Isolator (or disconnector) ⁽⁴⁾	■							
Switch ⁽⁵⁾	■	■	■ (1)	■ (1) (2)	■			
Residual device (RCCB) ⁽⁵⁾	■	■	■ (1)	■ (1) (2)	■			■
Switch-disconnector	■	■	■ (1)	■ (1) (2)	■			
Contactors		■	■ (1)	■ (1) (2)	■	■ (3)		
Remote control switch		■	■ (1)		■			
Fuse	■					■	■	
Circuit breaker		■	■ (1)	■ (1) (2)	■	■	■	
Circuit-breaker disconnector ⁽⁵⁾	■	■	■ (1)	■ (1) (2)	■	■	■	
Residual and overcurrent circuit-breaker (RCBO) ⁽⁵⁾	■	■	■ (1)	■ (1) (2)	■	■	■	■
Point of installation (general principle)	Origin of each circuit	All points where, for operational reasons it may be necessary to stop the process	In general at the incoming circuit to every distribution board	At the supply point to each machine and/or on the machine concerned	At the supply point to each machine	Origin of each circuit	Origin of each circuit	Origin of circuits where the earthing system is appropriate TN-S, IT, TT

H10

- (1) Where cut-off of all active conductors is provided
- (2) It may be necessary to maintain supply to a braking system
- (3) If it is associated with a thermal relay (the combination is commonly referred to as a “discontactor”)
- (4) In certain countries a disconnector with visible contacts is mandatory at the origin of a LV installation supplied directly from a MV/LV transformer
- (5) Certain items of switchgear are suitable for isolation duties (e.g. RCCBs according to IEC 61008) without being explicitly marked as such

Fig. H22 : Functions fulfilled by different items of switchgear

3.2 Switchgear selection

Software is being used more and more in the field of optimal selection of switchgear. Each circuit is considered one at a time, and a list is drawn up of the required protection functions and exploitation of the installation, among those mentioned in Figure H22 and summarized in Figure H1.

A number of switchgear combinations are studied and compared with each other against relevant criteria, with the aim of achieving:

- Satisfactory performance
- Compatibility among the individual items; from the rated current I_n to the fault-level rating I_{cu}
- Compatibility with upstream switchgear or taking into account its contribution
- Conformity with all regulations and specifications concerning safe and reliable circuit performance

In order to determine the number of poles for an item of switchgear, reference is made to chapter G, clause 7 Fig. G64. Multifunction switchgear, initially more costly, reduces installation costs and problems of installation or exploitation. It is often found that such switchgear provides the best solution.

4 Circuit-breaker

The circuit-breaker/disconnector fulfills all of the basic switchgear functions, while, by means of accessories, numerous other possibilities exist

As shown in **Figure H23** the circuit-breaker/ disconnector is the only item of switchgear capable of simultaneously satisfying all the basic functions necessary in an electrical installation.

Moreover, it can, by means of auxiliary units, provide a wide range of other functions, for example: indication (on-off - tripped on fault); undervoltage tripping; remote control... etc. These features make a circuit-breaker/ disconnector the basic unit of switchgear for any electrical installation.

Functions		Possible conditions
Isolation		■
Control	Functional	■
	Emergency switching	■ (With the possibility of a tripping coil for remote control)
	Switching-off for mechanical maintenance	■
Protection	Overload	■
	Short-circuit	■
	Insulation fault	■ (With differential-current relay)
	Undervoltage	■ (With undervoltage-trip coil)
Remote control		■ Added or incorporated
Indication and measurement		■ (Generally optional with an electronic tripping device)

Fig. H23 : Functions performed by a circuit-breaker/disconnector

Industrial circuit-breakers must comply with IEC 60947-1 and 60947-2 or other equivalent standards.
Domestic-type circuit-breakers must comply with IEC standard 60898, or an equivalent national standard

4.1 Standards and description

Standards

For industrial LV installations the relevant IEC standards are, or are due to be:

- 60947-1: general rules
- 60947-2: part 2: circuit-breakers
- 60947-3: part 3: switches, disconnectors, switch-disconnectors and fuse combination units
- 60947-4: part 4: contactors and motor starters
- 60947-5: part 5: control-circuit devices and switching elements
- 60947-6: part 6: multiple function switching devices
- 60947-7: part 7: ancillary equipment

For domestic and similar LV installations, the appropriate standard is IEC 60898, or an equivalent national standard.

Description

Figure H24 shows schematically the main parts of a LV circuit-breaker and its four essential functions:

- The circuit-breaking components, comprising the fixed and moving contacts and the arc-dividing chamber
- The latching mechanism which becomes unlatched by the tripping device on detection of abnormal current conditions
This mechanism is also linked to the operation handle of the breaker.
- A trip-mechanism actuating device:
 - Either: a thermal-magnetic device, in which a thermally-operated bi-metal strip detects an overload condition, while an electromagnetic striker pin operates at current levels reached in short-circuit conditions, or
 - An electronic relay operated from current transformers, one of which is installed on each phase
- A space allocated to the several types of terminal currently used for the main power circuit conductors

Domestic circuit-breakers (see **Fig. H25** next page) complying with IEC 60898 and similar national standards perform the basic functions of:

- Isolation
- Protection against overcurrent

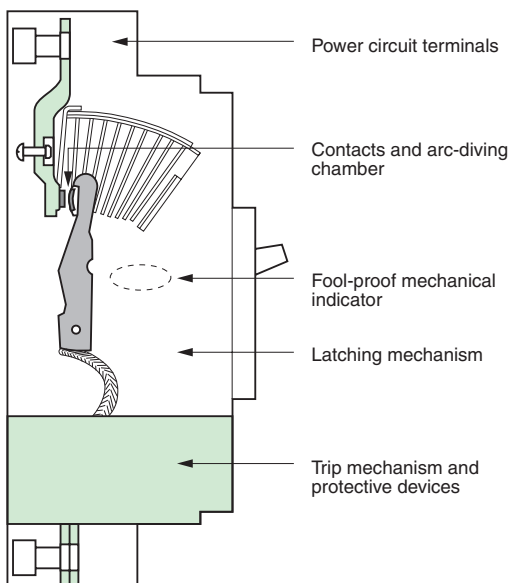

Fig. H24 : Main parts of a circuit-breaker

4 Circuit-breaker



Fig. H25 : Domestic-type circuit-breaker providing overcurrent protection and circuit isolation features

Some models can be adapted to provide sensitive detection (30 mA) of earth-leakage current with CB tripping, by the addition of a modular block, while other models (RCBOs, complying with IEC 61009 and CBRs complying with IEC 60947-2 Annex B) have this residual current feature incorporated as shown in **Figure H26**.

Apart from the above-mentioned functions further features can be associated with the basic circuit-breaker by means of additional modules, as shown in **Figure H27**; notably remote control and indication (on-off-fault).

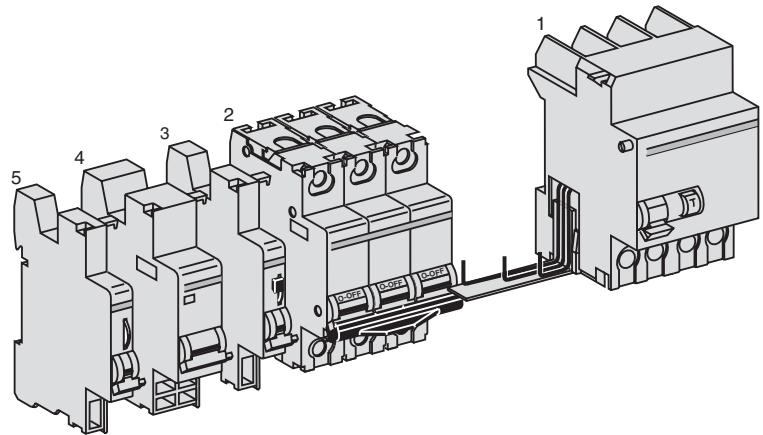

Fig. H27 : "Multi 9" system of LV modular switchgear components

H12



Fig. H26 : Domestic-type circuit-breaker as above (Fig. H25) with incorporated protection against electric shocks

Moulded-case circuit-breakers complying with IEC 60947-2 are available from 100 to 630 A and provide a similar range of auxiliary functions to those described above (see **Figure H28**).

Air circuit-breakers of large current ratings, complying with IEC 60947-2, are generally used in the main switch board and provide protector for currents from 630 A to 6300 A, typically.(see **Figure H29**).

In addition to the protection functions, the Micrologic unit provides optimized functions such as measurement (including power quality functions), diagnosis, communication, control and monitoring.



Fig. H28 : Example of a Compact NSX industrial type of circuit-breaker capable of numerous auxiliary functions

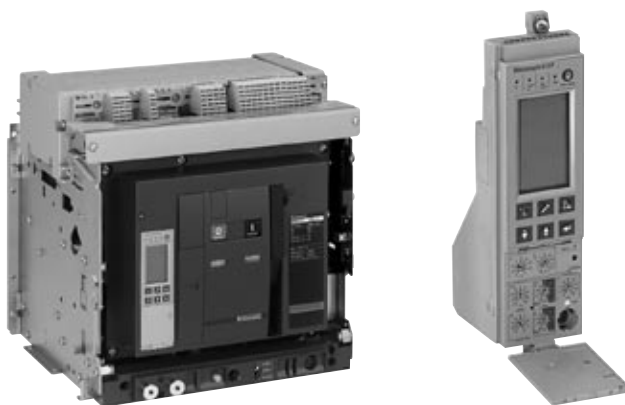

Fig. H29 : Example of air circuit-breakers. Masterpact provides many control features in its "Micrologic" tripping unit

4.2 Fundamental characteristics of a circuit-breaker

The fundamental characteristics of a circuit-breaker are:

- Its rated voltage U_e
- Its rated current I_n
- Its tripping-current-level adjustment ranges for overload protection ($I_r^{(1)}$ or $I_{rth}^{(1)}$) and for short-circuit protection ($I_m^{(1)}$)
- Its short-circuit current breaking rating (I_{cu} for industrial CBs; I_{cn} for domestic-type CBs).

Rated operational voltage (U_e)

This is the voltage at which the circuit-breaker has been designed to operate, in normal (undisturbed) conditions.

Other values of voltage are also assigned to the circuit-breaker, corresponding to disturbed conditions, as noted in sub-clause 4.3.

Rated current (I_n)

This is the maximum value of current that a circuit-breaker, fitted with a specified overcurrent tripping relay, can carry indefinitely at an ambient temperature stated by the manufacturer, without exceeding the specified temperature limits of the current carrying parts.

Example

A circuit-breaker rated at $I_n = 125$ A for an ambient temperature of 40°C will be equipped with a suitably calibrated overcurrent tripping relay (set at 125 A). The same circuit-breaker can be used at higher values of ambient temperature however, if suitably “derated”. Thus, the circuit-breaker in an ambient temperature of 50°C could carry only 117 A indefinitely, or again, only 109 A at 60°C , while complying with the specified temperature limit.

Derating a circuit-breaker is achieved therefore, by reducing the trip-current setting of its overload relay, and marking the CB accordingly. The use of an electronic-type of tripping unit, designed to withstand high temperatures, allows circuit-breakers (derated as described) to operate at 60°C (or even at 70°C) ambient.

Note: I_n for circuit-breakers (in IEC 60947-2) is equal to I_u for switchgear generally, I_u being the rated uninterrupted current.

Frame-size rating

A circuit-breaker which can be fitted with overcurrent tripping units of different current level-setting ranges, is assigned a rating which corresponds to the highest current-level-setting tripping unit that can be fitted.

Example

A Compact NSX630N circuit-breaker can be equipped with 11 electronic trip units from 150 A to 630 A. The size of the circuit-breaker is 630 A.

Overload relay trip-current setting (I_{rth} or I_r)

Apart from small circuit-breakers which are very easily replaced, industrial circuit-breakers are equipped with removable, i.e. exchangeable, overcurrent-trip relays. Moreover, in order to adapt a circuit-breaker to the requirements of the circuit it controls, and to avoid the need to install over-sized cables, the trip relays are generally adjustable. The trip-current setting I_r or I_{rth} (both designations are in common use) is the current above which the circuit-breaker will trip. It also represents the maximum current that the circuit-breaker can carry without tripping. That value must be greater than the maximum load current I_B , but less than the maximum current permitted in the circuit I_z (see chapter G, sub-clause 1.3).

The thermal-trip relays are generally adjustable from 0.7 to 1.0 times I_n , but when electronic devices are used for this duty, the adjustment range is greater; typically 0.4 to 1 times I_n .

Example (see Fig. H30)

A NSX630N circuit-breaker equipped with a 400 A Micrologic 6.3E overcurrent trip relay, set at 0.9, will have a trip-current setting:

$$I_r = 400 \times 0.9 = 360 \text{ A}$$

Note: For circuit-breakers equipped with non-adjustable overcurrent-trip relays, $I_r = I_n$. Example: for C60N 20 A circuit-breaker, $I_r = I_n = 20$ A.

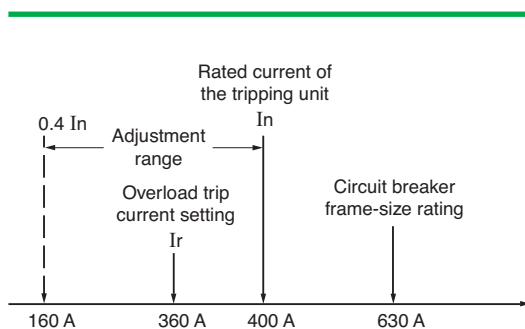

Fig. H30 : Example of a NSX630N circuit-breaker equipped with a Micrologic 6.3E trip unit adjusted to 0.9, to give $I_r = 360$ A

(1) Current-level setting values which refer to the current-operated thermal and “instantaneous” magnetic tripping devices for over-load and short-circuit protection.

Short-circuit relay trip-current setting (I_m)

Short-circuit tripping relays (instantaneous or slightly time-delayed) are intended to trip the circuit-breaker rapidly on the occurrence of high values of fault current. Their tripping threshold I_m is:

- Either fixed by standards for domestic type CBs, e.g. IEC 60898, or,
- Indicated by the manufacturer for industrial type CBs according to related standards, notably IEC 60947-2.

For the latter circuit-breakers there exists a wide variety of tripping devices which allow a user to adapt the protective performance of the circuit-breaker to the particular requirements of a load (see Fig. H31, Fig. H32 and Fig. H33).

	Type of protective relay	Overload protection	Short-circuit protection		
			Low setting	Standard setting	High setting
Domestic breakers IEC 60898	Thermal-magnetic	$I_r = I_n$	type B $3 I_n \leq I_m \leq 5 I_n$	type C $5 I_n \leq I_m \leq 10 I_n$	type D $10 I_n \leq I_m \leq 20 I_n^{(1)}$
Modular industrial ⁽²⁾ circuit-breakers	Thermal-magnetic	$I_r = I_n$ fixed	type B or Z $3.2 I_n \leq \text{fixed} \leq 4.8 I_n$	type C $7 I_n \leq \text{fixed} \leq 10 I_n$	type D or K $10 I_n \leq \text{fixed} \leq 14 I_n$
Industrial ⁽²⁾ circuit-breakers IEC 60947-2	Thermal-magnetic	$I_r = I_n$ fixed Adjustable: $0.7 I_n \leq I_r \leq I_n$	Fixed: $I_m = 7$ to $10 I_n$ Adjustable: - Low setting : 2 to $5 I_n$ - Standard setting: 5 to $10 I_n$		
	Electronic	Long delay $0.4 I_n \leq I_r \leq I_n$	Short-delay, adjustable $1.5 I_r \leq I_m \leq 10 I_r$ Instantaneous (I) fixed $I = 12$ to $15 I_n$		

(1) 50 In in IEC 60898, which is considered to be unrealistically high by most European manufacturers (Merlin Gerin = 10 to 14 In).
 (2) For industrial use, IEC standards do not specify values. The above values are given only as being those in common use.

Fig. H31 : Tripping-current ranges of overload and short-circuit protective devices for LV circuit-breakers

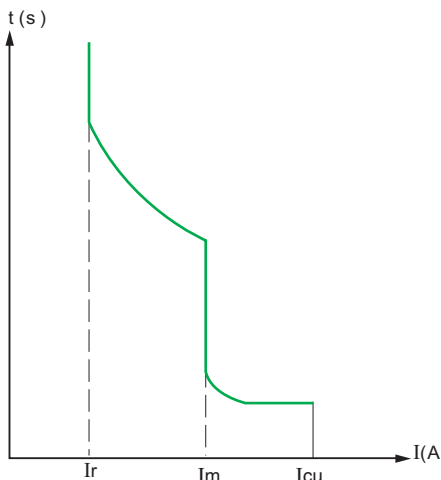
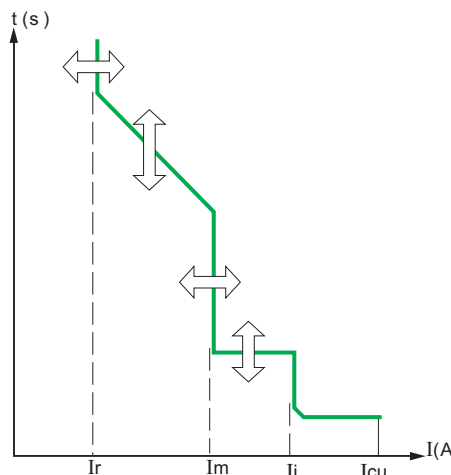

Fig. H32 : Performance curve of a circuit-breaker thermal-magnetic protective scheme



I_r : Overload (thermal or long-delay) relay trip-current setting
 I_m : Short-circuit (magnetic or short-delay) relay trip-current setting
 I_i : Short-circuit instantaneous relay trip-current setting.
 I_{cu} : Breaking capacity

Fig. H33 : Performance curve of a circuit-breaker electronic protective scheme

H14

The short-circuit current-breaking performance of a LV circuit-breaker is related (approximately) to the $\cos \varphi$ of the fault-current loop. Standard values for this relationship have been established in some standards

Isolating feature

A circuit-breaker is suitable for isolating a circuit if it fulfills all the conditions prescribed for a disconnecter (at its rated voltage) in the relevant standard (see sub-clause 1.2). In such a case it is referred to as a circuit-breaker-disconnector and marked on its front face with the symbol . All Multi 9, Compact NSX and Masterpact LV switchgear of Schneider Electric ranges are in this category.

Rated short-circuit breaking capacity (Icu or Icn)

The short-circuit current-breaking rating of a CB is the highest (prospective) value of current that the CB is capable of breaking without being damaged. The value of current quoted in the standards is the rms value of the AC component of the fault current, i.e. the DC transient component (which is always present in the worst possible case of short-circuit) is assumed to be zero for calculating the standardized value. This rated value (Icu) for industrial CBs and (Icn) for domestic-type CBs is normally given in kA rms.

Icu (rated ultimate s.c. breaking capacity) and Ics (rated service s.c. breaking capacity) are defined in IEC 60947-2 together with a table relating Ics with Icu for different categories of utilization A (instantaneous tripping) and B (time-delayed tripping) as discussed in subclause 4.3.

Tests for proving the rated s.c. breaking capacities of CBs are governed by standards, and include:

- Operating sequences, comprising a succession of operations, i.e. closing and opening on short-circuit
- Current and voltage phase displacement. When the current is in phase with the supply voltage ($\cos \varphi$ for the circuit = 1), interruption of the current is easier than that at any other power factor. Breaking a current at low lagging values of $\cos \varphi$ is considerably more difficult to achieve; a zero power-factor circuit being (theoretically) the most onerous case.

In practice, all power-system short-circuit fault currents are (more or less) at lagging power factors, and standards are based on values commonly considered to be representative of the majority of power systems. In general, the greater the level of fault current (at a given voltage), the lower the power factor of the fault-current loop, for example, close to generators or large transformers.

Figure H34 below extracted from IEC 60947-2 relates standardized values of $\cos \varphi$ to industrial circuit-breakers according to their rated Icu.

- Following an open - time delay - close/open sequence to test the Icu capacity of a CB, further tests are made to ensure that:
 - The dielectric withstand capability
 - The disconnection (isolation) performance and
 - The correct operation of the overload protection
 have not been impaired by the test.

Icu	$\cos \varphi$
6 kA < Icu ≤ 10 kA	0.5
10 kA < Icu ≤ 20 kA	0.3
20 kA < Icu ≤ 50 kA	0.25
50 kA < Icu	0.2

Fig. H34 : Icu related to power factor ($\cos \varphi$) of fault-current circuit (IEC 60947-2)

Familiarity with the following characteristics of LV circuit-breakers is often necessary when making a final choice.

4.3 Other characteristics of a circuit-breaker

Rated insulation voltage (Ui)

This is the value of voltage to which the dielectric tests voltage (generally greater than 2 Ui) and creepage distances are referred to.

The maximum value of rated operational voltage must never exceed that of the rated insulation voltage, i.e. $U_e \leq U_i$.

Rated impulse-withstand voltage (Uimp)

This characteristic expresses, in kV peak (of a prescribed form and polarity) the value of voltage which the equipment is capable of withstanding without failure, under test conditions.

Generally, for industrial circuit-breakers, $U_{imp} = 8 \text{ kV}$ and for domestic types, $U_{imp} = 6 \text{ kV}$.

Category (A or B) and rated short-time withstand current (Icw)

As already briefly mentioned (sub-clause 4.2) there are two categories of LV industrial switchgear, A and B, according to IEC 60947-2:

- Those of category A, for which there is no deliberate delay in the operation of the “instantaneous” short-circuit magnetic tripping device (see Fig. H35), are generally moulded-case type circuit-breakers, and
- Those of category B for which, in order to discriminate with other circuit-breakers on a time basis, it is possible to delay the tripping of the CB, where the fault-current level is lower than that of the short-time withstand current rating (Icw) of the CB (see Fig. H36). This is generally applied to large open-type circuit-breakers and to certain heavy-duty moulded-case types. Icw is the maximum current that the B category CB can withstand, thermally and electro-dynamically, without sustaining damage, for a period of time given by the manufacturer.

Rated making capacity (Icm)

Icm is the highest instantaneous value of current that the circuit-breaker can establish at rated voltage in specified conditions. In AC systems this instantaneous peak value is related to Icu (i.e. to the rated breaking current) by the factor k, which depends on the power factor (cos φ) of the short-circuit current loop (as shown in Figure H37).

Icu	cos φ	Icm = kIcu
6 kA < Icu ≤ 10 kA	0.5	1.7 x Icu
10 kA < Icu ≤ 20 kA	0.3	2 x Icu
20 kA < Icu ≤ 50 kA	0.25	2.1 x Icu
50 kA ≤ Icu	0.2	2.2 x Icu

Fig. H37 : Relation between rated breaking capacity Icu and rated making capacity Icm at different power-factor values of short-circuit current, as standardized in IEC 60947-2

Example: A Masterpact NW08H2 circuit-breaker has a rated breaking capacity Icu of 100 kA. The peak value of its rated making capacity Icm will be $100 \times 2.2 = 220 \text{ kA}$.

Rated service short-circuit breaking capacity (Ics)

The rated breaking capacity (Icu) or (Icn) is the maximum fault-current a circuit-breaker can successfully interrupt without being damaged. The probability of such a current occurring is extremely low, and in normal circumstances the fault-currents are considerably less than the rated breaking capacity (Icu) of the CB. On the other hand it is important that high currents (of low probability) be interrupted under good conditions, so that the CB is immediately available for reclosure, after the faulty circuit has been repaired. It is for these reasons that a new characteristic (Ics) has been created, expressed as a percentage of Icu, viz: 25, 50, 75, 100% for industrial circuit-breakers. The standard test sequence is as follows:

- O - CO - CO⁽¹⁾ (at Ics)
 - Tests carried out following this sequence are intended to verify that the CB is in a good state and available for normal service
- For domestic CBs, $I_{cs} = k I_{cn}$. The factor k values are given in IEC 60898 table XIV. In Europe it is the industrial practice to use a k factor of 100% so that $I_{cs} = I_{cu}$.

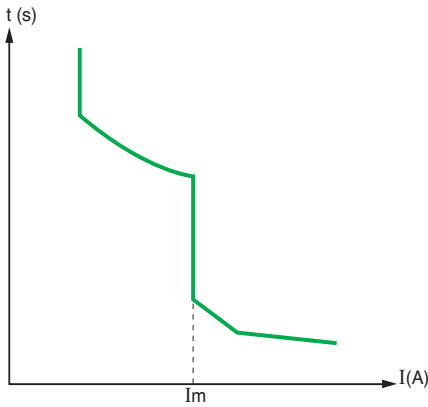

Fig. H35 : Category A circuit-breaker

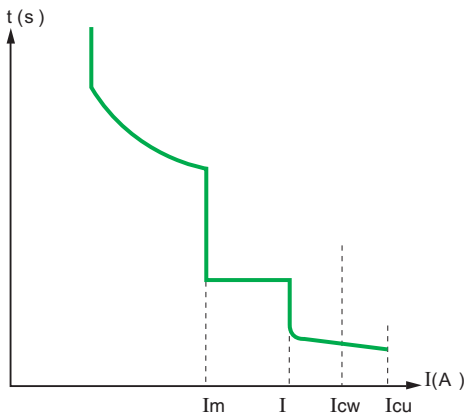

Fig. H36 : Category B circuit-breaker

In a correctly designed installation, a circuit-breaker is never required to operate at its maximum breaking current Icu. For this reason a new characteristic Ics has been introduced. It is expressed in IEC 60947-2 as a percentage of Icu (25, 50, 75, 100%)

(1) O represents an opening operation.
CO represents a closing operation followed by an opening operation.

Many designs of LV circuit-breakers feature a short-circuit current limitation capability, whereby the current is reduced and prevented from reaching its (otherwise) maximum peak value (see Fig. H38). The current-limitation performance of these CBs is presented in the form of graphs, typified by that shown in Figure H39, diagram (a)

Fault-current limitation

The fault-current limitation capacity of a CB concerns its ability, more or less effective, in preventing the passage of the maximum prospective fault-current, permitting only a limited amount of current to flow, as shown in **Figure H38**. The current-limitation performance is given by the CB manufacturer in the form of curves (see **Fig. H39**).

- Diagram (a) shows the limited peak value of current plotted against the rms value of the AC component of the prospective fault current ("prospective" fault-current refers to the fault-current which would flow if the CB had no current-limiting capability)
- Limitation of the current greatly reduces the thermal stresses (proportional I^2t) and this is shown by the curve of diagram (b) of Figure H39, again, versus the rms value of the AC component of the prospective fault current.

LV circuit-breakers for domestic and similar installations are classified in certain standards (notably European Standard EN 60 898). CBs belonging to one class (of current limiters) have standardized limiting I^2t let-through characteristics defined by that class.

In these cases, manufacturers do not normally provide characteristic performance curves.

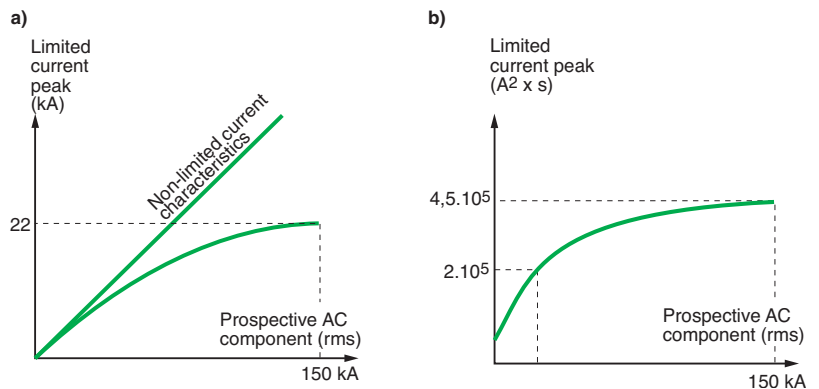

Fig. H39 : Performance curves of a typical LV current-limiting circuit-breaker

Current limitation reduces both thermal and electrodynamic stresses on all circuit elements through which the current passes, thereby prolonging the useful life of these elements. Furthermore, the limitation feature allows "cascading" techniques to be used (see 4.5) thereby significantly reducing design and installation costs

The advantages of current limitation

The use of current-limiting CBs affords numerous advantages:

- Better conservation of installation networks: current-limiting CBs strongly attenuate all harmful effects associated with short-circuit currents
- Reduction of thermal effects: Conductors (and therefore insulation) heating is significantly reduced, so that the life of cables is correspondingly increased
- Reduction of mechanical effects: forces due to electromagnetic repulsion are lower, with less risk of deformation and possible rupture, excessive burning of contacts, etc.
- Reduction of electromagnetic-interference effects:
 - Less influence on measuring instruments and associated circuits, telecommunication systems, etc.

These circuit-breakers therefore contribute towards an improved exploitation of:

- Cables and wiring
- Prefabricated cable-trunking systems
- Switchgear, thereby reducing the ageing of the installation

Example

On a system having a prospective shortcircuit current of 150 kA rms, a Compact L circuit-breaker limits the peak current to less than 10% of the calculated prospective peak value, and the thermal effects to less than 1% of those calculated.

Cascading of the several levels of distribution in an installation, downstream of a limiting CB, will also result in important savings.

The technique of cascading, described in sub-clause 4.5 allows, in fact, substantial savings on switchgear (lower performance permissible downstream of the limiting CB(s)) enclosures, and design studies, of up to 20% (overall).

Discriminative protection schemes and cascading are compatible, in the Compact NSX range, up to the full short-circuit breaking capacity of the switchgear.

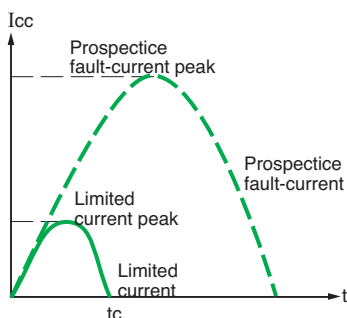

Fig. H38 : Prospective and actual currents

The choice of a range of circuit-breakers is determined by: the electrical characteristics of the installation, the environment, the loads and a need for remote control, together with the type of telecommunications system envisaged

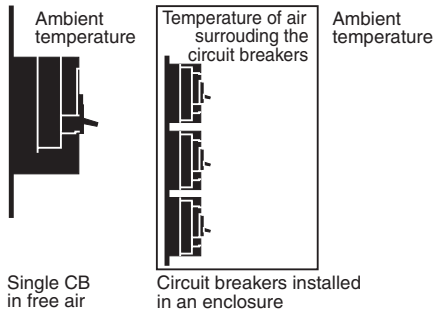

Fig. H40 : Ambient temperature

H18

Circuit-breakers with uncompensated thermal tripping units have a trip current level that depends on the surrounding temperature

4.4 Selection of a circuit-breaker

Choice of a circuit-breaker

The choice of a CB is made in terms of:

- Electrical characteristics of the installation for which the CB is intended
- Its eventual environment: ambient temperature, in a kiosk or switchboard enclosure, climatic conditions, etc.
- Short-circuit current breaking and making requirements
- Operational specifications: discriminative tripping, requirements (or not) for remote control and indication and related auxiliary contacts, auxiliary tripping coils, connection
- Installation regulations; in particular: protection of persons
- Load characteristics, such as motors, fluorescent lighting, LV/LV transformers

The following notes relate to the choice LV circuit-breaker for use in distribution systems.

Choice of rated current in terms of ambient temperature

The rated current of a circuit-breaker is defined for operation at a given ambient temperature, in general:

- 30 °C for domestic-type CBs
- 40 °C for industrial-type CBs

Performance of these CBs in a different ambient temperature depends mainly on the technology of their tripping units (see Fig. H40).

Uncompensated thermal magnetic tripping units

Circuit-breakers with uncompensated thermal tripping elements have a tripping-current level that depends on the surrounding temperature. If the CB is installed in an enclosure, or in a hot location (boiler room, etc.), the current required to trip the CB on overload will be sensibly reduced. When the temperature in which the CB is located exceeds its reference temperature, it will therefore be “derated”. For this reason, CB manufacturers provide tables which indicate factors to apply at temperatures different to the CB reference temperature. It may be noted from typical examples of such tables (see Fig. H41) that a lower temperature than the reference value produces an up-rating of the CB. Moreover, small modular-type CBs mounted in juxtaposition, as shown typically in Figure H27, are usually mounted in a small closed metal case. In this situation, mutual heating, when passing normal load currents, generally requires them to be derated by a factor of 0.8.

Example

What rating (I_n) should be selected for a C60 N?

- Protecting a circuit, the maximum load current of which is estimated to be 34 A
- Installed side-by-side with other CBs in a closed distribution box
- In an ambient temperature of 50 °C

A C60N circuit-breaker rated at 40 A would be derated to 35.6 A in ambient air at 50 °C (see Fig. H41). To allow for mutual heating in the enclosed space, however, the 0.8 factor noted above must be employed, so that, $35.6 \times 0.8 = 28.5$ A, which is not suitable for the 34 A load.

A 50 A circuit-breaker would therefore be selected, giving a (derated) current rating of $44 \times 0.8 = 35.2$ A.

Compensated thermal-magnetic tripping units

These tripping units include a bi-metal compensating strip which allows the overload trip-current setting (I_r or I_{rth}) to be adjusted, within a specified range, irrespective of the ambient temperature.

For example:

- In certain countries, the TT system is standard on LV distribution systems, and domestic (and similar) installations are protected at the service position by a circuit-breaker provided by the supply authority. This CB, besides affording protection against indirect-contact hazard, will trip on overload; in this case, if the consumer exceeds the current level stated in his supply contract with the power authority. The circuit-breaker (≤ 60 A) is compensated for a temperature range of - 5 °C to + 40 °C.
- LV circuit-breakers at ratings ≤ 630 A are commonly equipped with compensated tripping units for this range (- 5 °C to + 40 °C)

C60a, C60H: curve C. C60N: curves B and C (reference temperature: 30 °C)

Rating (A)	20 °C	25 °C	30 °C	35 °C	40 °C	45 °C	50 °C	55 °C	60 °C
1	1.05	1.02	1.00	0.98	0.95	0.93	0.90	0.88	0.85
2	2.08	2.04	2.00	1.96	1.92	1.88	1.84	1.80	1.74
3	3.18	3.09	3.00	2.91	2.82	2.70	2.61	2.49	2.37
4	4.24	4.12	4.00	3.88	3.76	3.64	3.52	3.36	3.24
6	6.24	6.12	6.00	5.88	5.76	5.64	5.52	5.40	5.30
10	10.6	10.3	10.0	9.70	9.30	9.00	8.60	8.20	7.80
16	16.8	16.5	16.0	15.5	15.2	14.7	14.2	13.8	13.5
20	21.0	20.6	20.0	19.4	19.0	18.4	17.8	17.4	16.8
25	26.2	25.7	25.0	24.2	23.7	23.0	22.2	21.5	20.7
32	33.5	32.9	32.0	31.4	30.4	29.8	28.4	28.2	27.5
40	42.0	41.2	40.0	38.8	38.0	36.8	35.6	34.4	33.2
50	52.5	51.5	50.0	48.5	47.4	45.5	44.0	42.5	40.5
63	66.2	64.9	63.0	61.1	58.0	56.7	54.2	51.7	49.2

Compact NSX100-250 N/H/L equipment with TM-D or TM-G trip units

Rating (A)	Temperature (°C)												
	10	15	20	25	30	35	40	45	50	55	60	65	70
16	18.4	18.7	18	18	17	16.6	16	15.6	15.2	14.8	14.5	14	13.8
25	28.8	28	27.5	25	26.3	25.6	25	24.5	24	23.5	23	22	21
32	36.8	36	35.2	34.4	33.6	32.8	32	31.3	30.5	30	29.5	29	28.5
40	46	45	44	43	42	41	40	39	38	37	36	35	34
50	57.5	56	55	54	52.5	51	50	49	48	47	46	45	44
63	72	71	69	68	66	65	63	61.5	60	58	57	55	54
80	92	90	88	86	84	82	80	78	76	74	72	70	68
100	115	113	110	108	105	103	100	97.5	95	92.5	90	87.5	85
125	144	141	138	134	131	128	125	122	119	116	113	109	106
160	184	180	176	172	168	164	160	156	152	148	144	140	136
200	230	225	220	215	210	205	200	195	190	185	180	175	170
250	288	281	277	269	263	256	250	244	238	231	225	219	213

Fig. H41 : Examples of tables for the determination of derating/uprating factors to apply to CBs with uncompensated thermal tripping units, according to temperature

Electronic tripping units are highly stable in changing temperature levels

Electronic trip units

An important advantage with electronic tripping units is their stable performance in changing temperature conditions. However, the switchgear itself often imposes operational limits in elevated temperatures, so that manufacturers generally provide an operating chart relating the maximum values of permissible trip-current levels to the ambient temperature (see **Fig. H42**).

Moreover, electronic trip units can provide information that can be used for a better management of the electrical distribution, including energy efficiency and power quality.

Masterpact NW20 version		40°C	45°C	50°C	55°C	60°C	
H1/H2/H3	Withdrawable with horizontal plugs	In (A)	2,000	2,000	2,000	1,980	1,890
		Maximum adjustment Ir	1	1	1	0.99	0.95
L1	Withdrawable with on-edge plugs	In (A)	2,000	200	1,900	1,850	1,800
		Maximum adjustment Ir	1	1	0.95	0.93	0.90

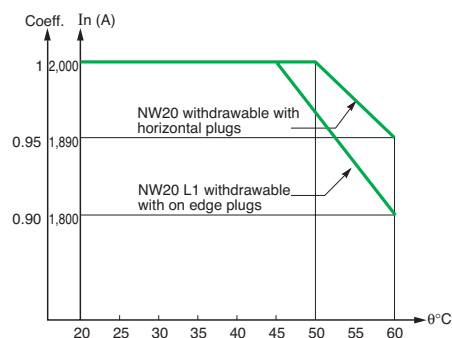

Fig. H42 : Derating of Masterpact NW20 circuit-breaker, according to the temperature

Selection of an instantaneous, or short-time-delay, tripping threshold

Figure H43 below summarizes the main characteristics of the instantaneous or short-time delay trip units.

Type	Tripping unit	Applications
	Low setting type B	<ul style="list-style-type: none"> ■ Sources producing low short-circuit-current levels (standby generators) ■ Long lengths of line or cable
	Standard setting type C	<ul style="list-style-type: none"> ■ Protection of circuits: general case
	High setting type D or K	<ul style="list-style-type: none"> ■ Protection of circuits having high initial transient current levels (e.g. motors, transformers, resistive loads)
	12 In type MA	<ul style="list-style-type: none"> ■ Protection of motors in association with disconnectors (contactors with overload protection)

Fig. H43 : Different tripping units, instantaneous or short-time-delayed

The installation of a LV circuit-breaker requires that its short-circuit breaking capacity (or that of the CB together with an associated device) be equal to or exceeds the calculated prospective short-circuit current at its point of installation

Selection of a circuit-breaker according to the short-circuit breaking capacity requirements

The installation of a circuit-breaker in a LV installation must fulfil one of the two following conditions:

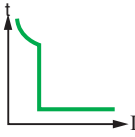
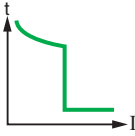
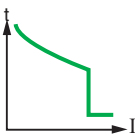
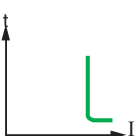
- Either have a rated short-circuit breaking capacity I_{cu} (or I_{cn}) which is equal to or exceeds the prospective short-circuit current calculated for its point of installation, or
- If this is not the case, be associated with another device which is located upstream, and which has the required short-circuit breaking capacity

In the second case, the characteristics of the two devices must be co-ordinated such that the energy permitted to pass through the upstream device must not exceed that which the downstream device and all associated cables, wires and other components can withstand, without being damaged in any way. This technique is profitably employed in:

- Associations of fuses and circuit-breakers
 - Associations of current-limiting circuit-breakers and standard circuit-breakers.
- The technique is known as “cascading” (see sub-clause 4.5 of this chapter)

The selection of main and principal circuit-breakers

A single transformer

If the transformer is located in a consumer’s substation, certain national standards require a LV circuit-breaker in which the open contacts are clearly visible such as Compact NSX withdrawable circuit-breaker.

Example (see Fig. H44 opposite page)

What type of circuit-breaker is suitable for the main circuit-breaker of an installation supplied through a 250 kVA MV/LV (400 V) 3-phase transformer in a consumer’s substation?

In transformer = 360 A

I_{sc} (3-phase) = 8.9 kA

A Compact NSX400N with an adjustable tripping-unit range of 160 A - 400 A and a short-circuit breaking capacity (I_{cu}) of 50 kA would be a suitable choice for this duty.

H20

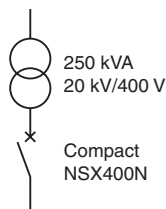

Fig. H44 : Example of a transformer in a consumer's substation

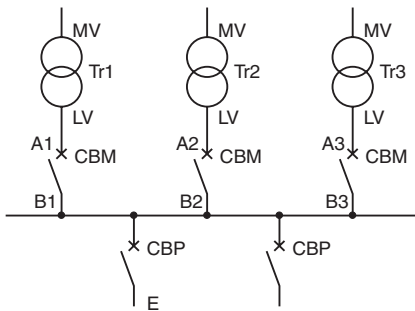

Fig. H45 : Transformers in parallel

Several transformers in parallel (see Fig. H45)

- The circuit-breakers CBP outgoing from the LV distribution board must each be capable of breaking the total fault current from all transformers connected to the busbars, viz: $I_{sc1} + I_{sc2} + I_{sc3}$
- The circuit-breakers CBM, each controlling the output of a transformer, must be capable of dealing with a maximum short-circuit current of (for example) $I_{sc2} + I_{sc3}$ only, for a short-circuit located on the upstream side of CBM1. From these considerations, it will be seen that the circuit-breaker of the smallest transformer will be subjected to the highest level of fault current in these circumstances, while the circuit-breaker of the largest transformer will pass the lowest level of short-circuit current
- The ratings of CBMs must be chosen according to the kVA ratings of the associated transformers

Note: The essential conditions for the successful operation of 3-phase transformers in parallel may be summarized as follows:

1. the phase shift of the voltages, primary to secondary, must be the same in all units to be paralleled.
 2. the open-circuit voltage ratios, primary to secondary, must be the same in all units.
 3. the short-circuit impedance voltage ($Z_{sc}\%$) must be the same for all units.
- For example, a 750 kVA transformer with a $Z_{sc} = 6\%$ will share the load correctly with a 1,000 kVA transformer having a Z_{sc} of 6%, i.e. the transformers will be loaded automatically in proportion to their kVA ratings. For transformers having a ratio of kVA ratings exceeding 2, parallel operation is not recommended.

Figure H46 indicates, for the most usual arrangement (2 or 3 transformers of equal kVA ratings) the maximum short-circuit currents to which main and principal CBs (CBM and CBP respectively, in Figure H45) are subjected. It is based on the following hypotheses:

- The short-circuit 3-phase power on the MV side of the transformer is 500 MVA
- The transformers are standard 20/0.4 kV distribution-type units rated as listed
- The cables from each transformer to its LV circuit-breaker comprise 5 metres of single core conductors
- Between each incoming-circuit CBM and each outgoing-circuit CBP there is 1 metre of busbar
- The switchgear is installed in a floor-mounted enclosed switchboard, in an ambient-air temperature of 30 °C

Moreover, this table shows selected circuit-breakers of M-G manufacture recommended for main and principal circuit-breakers in each case.

Example (see Fig. H47 next page)

■ Circuit-breaker selection for CBM duty:
For a 800 kVA transformer $I_n = 1.126$ A; I_{cu} (minimum) = 38 kA (from Figure H46), the CBM indicated in the table is a Compact NS1250N ($I_{cu} = 50$ kA)

■ Circuit-breaker selection for CBP duty:
The s.c. breaking capacity (I_{cu}) required for these circuit-breakers is given in the Figure H46 as 56 kA.
A recommended choice for the three outgoing circuits 1, 2 and 3 would be current-limiting circuit-breakers types NSX400 L, NSX250 L and NSX100 L. The I_{cu} rating in each case = 150 kA.

Number and kVA ratings of 20/0.4 kV transformers	Minimum S.C breaking capacity of main CBs (I_{cu}) kA	Main circuit-breakers (CBM) total discrimination with outgoing circuit-breakers (CBP)	Minimum S.C breaking capacity of principal CBs (I_{cu}) kA	Rated current I_n of principal circuit-breaker (CPB) 250A
2 x 400	14	NW08N1/NS800N	27	NSX250H
3 x 400	28	NW08N1/NS800N	42	NSX250H
2 x 630	22	NW10N1/NS1000N	42	NSX250H
3 x 630	44	NW10N1/NS1000N	67	NSX250H
2 x 800	19	NW12N1/NS1250N	38	NSX250H
3 x 800	38	NW12N1/NS1250N	56	NSX250H
2 x 1,000	23	NW16N1/NS1600N	47	NSX250H
3 x 1,000	47	NW16N1/NS1600N	70	NSX250H
2 x 1,250	29	NW20N1/NS2000N	59	NSX250H
3 x 1,250	59	NW20N1/NS2000N	88	NSX250L
2 x 1,600	38	NW25N1/NS2500N	75	NSX250L
3 x 1,600	75	NW25N1/NS2500N	113	NSX250L
2 x 2,000	47	NW32N1/NS3200N	94	NSX250L
3 x 2,000	94	NW32N1/NS3200N	141	NSX250L

Fig. H46 : Maximum values of short-circuit current to be interrupted by main and principal circuit-breakers (CBM and CBP respectively), for several transformers in parallel

Short-circuit fault-current levels at any point in an installation may be obtained from tables

These circuit-breakers provide the advantages of:

- Absolute discrimination with the upstream (CBM) breakers
- Exploitation of the “cascading” technique, with its associated savings for all downstream components

Choice of outgoing-circuit CBs and final-circuit CBs

Use of table G40

From this table, the value of 3-phase short-circuit current can be determined rapidly for any point in the installation, knowing:

- The value of short-circuit current at a point upstream of that intended for the CB concerned
- The length, c.s.a., and the composition of the conductors between the two points

A circuit-breaker rated for a short-circuit breaking capacity exceeding the tabulated value may then be selected.

Detailed calculation of the short-circuit current level

In order to calculate more precisely the short-circuit current, notably, when the short-circuit current-breaking capacity of a CB is slightly less than that derived from the table, it is necessary to use the method indicated in chapter G clause 4.

Two-pole circuit-breakers (for phase and neutral) with one protected pole only

These CBs are generally provided with an overcurrent protective device on the phase pole only, and may be used in TT, TN-S and IT schemes. In an IT scheme, however, the following conditions must be respected:

- Condition (B) of table G67 for the protection of the neutral conductor against overcurrent in the case of a double fault
- Short-circuit current-breaking rating: A 2-pole phase-neutral CB must, by convention, be capable of breaking on one pole (at the phase-to-phase voltage) the current of a double fault equal to 15% of the 3-phase short-circuit current at the point of its installation, if that current is ≤ 10 kA; or 25% of the 3-phase short-circuit current if it exceeds 10 kA
- Protection against indirect contact: this protection is provided according to the rules for IT schemes

Insufficient short-circuit current breaking rating

In low-voltage distribution systems it sometimes happens, especially in heavy-duty networks, that the I_{sc} calculated exceeds the I_{cu} rating of the CBs available for installation, or system changes upstream result in lower level CB ratings being exceeded

- Solution 1: Check whether or not appropriate CBs upstream of the CBs affected are of the current-limiting type, allowing the principle of cascading (described in sub-clause 4.5) to be applied
- Solution 2: Install a range of CBs having a higher rating. This solution is economically interesting only where one or two CBs are affected
- Solution 3: Associate current-limiting fuses (gG or aM) with the CBs concerned, on the upstream side. This arrangement must, however, respect the following rules:
 - The fuse rating must be appropriate
 - No fuse in the neutral conductor, except in certain IT installations where a double fault produces a current in the neutral which exceeds the short-circuit breaking rating of the CB. In this case, the blowing of the neutral fuse must cause the CB to trip on all phases

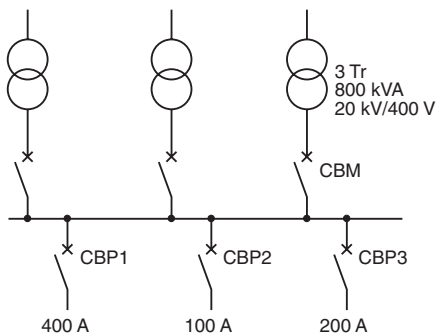

Fig. H47 : Transformers in parallel

The technique of “cascading” uses the properties of current-limiting circuit-breakers to permit the installation of all downstream switchgear, cables and other circuit components of significantly lower performance than would otherwise be necessary, thereby simplifying and reducing the cost of an installation

4.5 Coordination between circuit-breakers

Cascading

Definition of the cascading technique

By limiting the peak value of short-circuit current passing through it, a current-limiting CB permits the use, in all circuits downstream of its location, of switchgear and circuit components having much lower short-circuit breaking capacities, and thermal and electromechanical withstand capabilities than would otherwise be necessary. Reduced physical size and lower performance requirements lead to substantial economy and to the simplification of installation work. It may be noted that, while a current-limiting circuit-breaker has the effect on downstream circuits of (apparently) increasing the source impedance during short-circuit conditions, it has no such effect in any other condition; for example, during the starting of a large motor (where a low source impedance is highly desirable). The range of Compact NSX current-limiting circuit-breakers with powerful limiting performances is particularly interesting.

In general, laboratory tests are necessary to ensure that the conditions of implementation required by national standards are met and compatible switchgear combinations must be provided by the manufacturer

Conditions of implementation

Most national standards admit the cascading technique, on condition that the amount of energy “let through” by the limiting CB is less than the energy all downstream CBs and components are able to withstand without damage.

In practice this can only be verified for CBs by tests performed in a laboratory. Such tests are carried out by manufacturers who provide the information in the form of tables, so that users can confidently design a cascading scheme based on the combination of recommended circuit-breaker types. As an example, **Figure H48** indicates the cascading possibilities of circuit-breaker types C60, DT40N, C120 and NG125 when installed downstream of current-limiting CBs Compact NSX 250 N, H or L for a 230/400 V or 240/415 V 3-phase installation.

	kA rms			
Short-circuit breaking capacity of the upstream (limiter) CBs	150			NSX250L
	70		NSX250H	
	50	NSX250N		
Possible short-circuit breaking capacity of the downstream CBs (benefiting from the cascading technique)	150			NG125L
	70		NG125L	
	36	NG125N	NG125N	
	30	C60N/H<=32A	C60N/H<=32A	C60N/H<=32A
	30	C60L<=25A	C60L<=25A Quick PRD 40/20/8	C60L<=25A
	25	C60H>=40A C120N/H	C60H>=40A C120N/H	C60H>=40A C120N/H
	20	C60N>=40A	C60N>=40A	C60N>=40A

Fig. H48 : Example of cascading possibilities on a 230/400 V or 240/415 V 3-phase installation

Advantages of cascading

The current limitation benefits all downstream circuits that are controlled by the current-limiting CB concerned.

The principle is not restrictive, i.e. current-limiting CBs can be installed at any point in an installation where the downstream circuits would otherwise be inadequately rated.

The result is:

- Simplified short-circuit current calculations
- Simplification, i.e. a wider choice of downstream switchgear and appliances
- The use of lighter-duty switchgear and appliances, with consequently lower cost
- Economy of space requirements, since light-duty equipment have generally a smaller volume

Principles of discriminative tripping (selectivity)

Discrimination is achieved by automatic protective devices if a fault condition, occurring at any point in the installation, is cleared by the protective device located immediately upstream of the fault, while all other protective devices remain unaffected (see **Fig. H49**).

Discrimination may be total or partial, and based on the principles of current levels, or time-delays, or a combination of both. A more recent development is based on the logic techniques.

The Schneider Electric system takes advantages of both current-limitation and discrimination

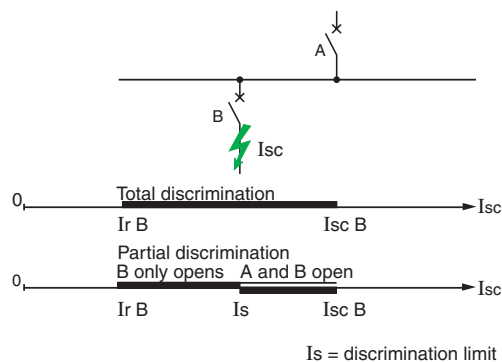

Fig. H49 : Total and partial discrimination

H24

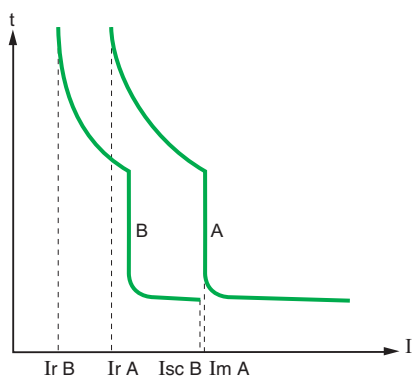

Fig. H50 : Total discrimination between CBs A and B

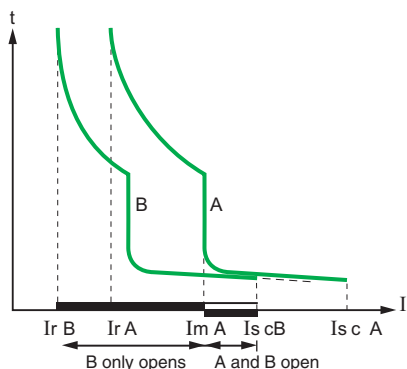

Fig. H51 : Partial discrimination between CBs A and B

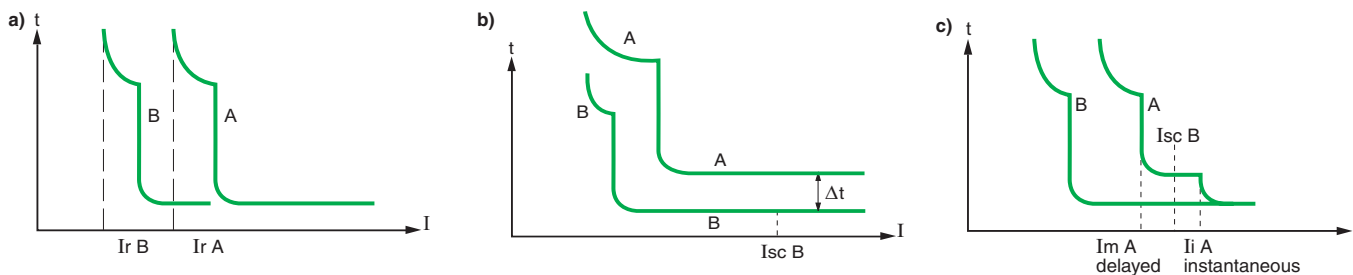

Fig. H52 : Discrimination

Discrimination between circuit-breakers A and B is total if the maximum value of short-circuit-current on circuit B ($I_{sc B}$) does not exceed the short-circuit trip setting of circuit-breaker A ($I_m A$). For this condition, B only will trip (see Fig. H50).

Discrimination is partial if the maximum possible short-circuit current on circuit B exceeds the short-circuit trip-current setting of circuit-breaker A. For this maximum condition, both A and B will trip (see Fig. H51).

Protection against overload : discrimination based on current levels (see Fig. H52a)

This method is realized by setting successive tripping thresholds at stepped levels, from downstream relays (lower settings) towards the source (higher settings). Discrimination is total or partial, depending on particular conditions, as noted above. As a rule of thumb, discrimination is achieved when:

- $I_r A / I_r B > 2$:

Protection against low level short-circuit currents : discrimination based on stepped time delays (see Fig. H52b)

This method is implemented by adjusting the time-delayed tripping units, such that downstream relays have the shortest operating times, with progressively longer delays towards the source.

In the two-level arrangement shown, upstream circuit-breaker A is delayed sufficiently to ensure total discrimination with B (for example: Masterpact with electronic trip unit).

Discrimination based on a combination of the two previous methods (see Fig. H52c)

A time-delay added to a current level scheme can improve the overall discrimination performance.

The upstream CB has two high-speed magnetic tripping thresholds:

- $I_m A$: delayed magnetic trip or short-delay electronic trip
- I_i : instantaneous strip

Discrimination is total if $I_{sc B} < I_i$ (instantaneous).

Protection against high level short-circuit currents: discrimination based on arc-energy levels

This technology implemented in the Compact NSX range (current limiting circuit-breaker) is extremely effective for achievement of total discrimination.

Principle: When a very high level short-circuit current is detected by the two circuit-breaker A and B, their contacts open simultaneously. As a result, the current is highly limited.

- The very high arc-energy at level B induces the tripping of circuit-breaker B
- Then, the arc-energy is limited at level A and is not sufficient to induce the tripping of A

As a rule of thumb, the discrimination between Compact NSX is total if the size ratio between A and B is greater than 2.5.

Current-level discrimination

This technique is directly linked to the staging of the Long Time (LT) tripping curves of two serial-connected circuit-breakers.

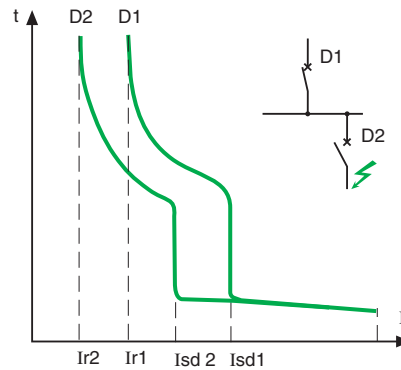

Fig. H53 : Current discrimination

The discrimination limit I_s is:

- $I_s = I_{sd2}$ if the thresholds I_{sd1} and I_{sd2} are too close or merge,
- $I_s = I_{sd1}$ if the thresholds I_{sd1} and I_{sd2} are sufficiently far apart.

As a rule, current discrimination is achieved when:

- $I_{r1} / I_{r2} < 2$,
- $I_{sd1} / I_{sd2} > 2$.

The discrimination limit is:

- $I_s = I_{sd1}$.

Discrimination quality

Discrimination is total if $I_s > I_{sc}(D2)$, i.e. $I_{sd1} > I_{sc}(D2)$.

This normally implies:

- a relatively low level $I_{sc}(D2)$,
- a large difference between the ratings of circuit-breakers D1 and D2.

Current discrimination is normally used in final distribution.

Discrimination based on time-delayed tripping uses CBs referred to as “selective” (in some countries).

Implementation of these CBs is relatively simple and consists in delaying the instant of tripping of the several series-connected circuit-breakers in a stepped time sequence

Time discrimination

This is the extension of current discrimination and is obtained by staging over time of the tripping curves. This technique consists of giving a time delay of t to the Short Time (ST) tripping of D1.

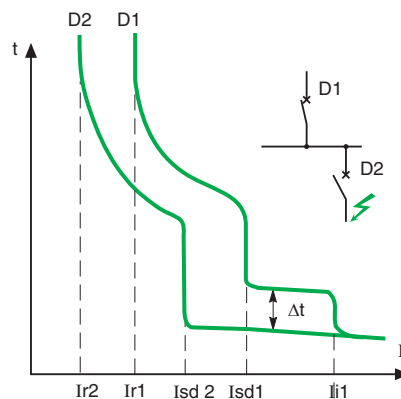

Fig. H54 : Time discrimination

The thresholds (I_{r1} , I_{sd1}) of D1 and (I_{r2} , I_{sd2}) comply with the staging rules of current discrimination.
 The discrimination limit I_s of the association is at least equal to I_{i1} , the instantaneous threshold of D1.

Discrimination quality

There are two possible applications:

■ **on final and/or intermediate feeders**

A category circuit-breakers can be used with time-delayed tripping of the upstream circuit-breaker. This allows extension of current discrimination up to the instantaneous threshold I_{i1} of the upstream circuit-breaker: $I_s = I_{i1}$.

If $I_{sc}(D2)$ is not too high - case of a final feeder - total discrimination can be obtained.

■ **on the incomers and feeders of the MSB**

At this level, as continuity of supply takes priority, the installation characteristics allow use of **B category circuit-breakers** designed for time-delayed tripping. These circuit-breakers have a high thermal withstand ($I_{cw} \geq 50\% I_{cn}$ for $t = 1s$): $I_s = I_{cw1}$.

Even for high $I_{sc}(D2)$, time discrimination normally provides total discrimination: $I_{cw1} > I_{cc}(D2)$.

Note: Use of B category circuit-breakers means that the installation must withstand high electrodynamic and thermal stresses. Consequently, these circuit-breakers have a high instantaneous threshold I_i that can be adjusted and disabled in order to protect the busbars if necessary.

Practical example of discrimination at several levels with Schneider Electric circuit-breakers (with electronic trip units)

"Masterpact NT is totally selective with any moulded-case Compact NSX circuit breaker, i.e., the downstream circuit-breaker will trip for any short-circuit value up to its breaking capacity. Further, all Compact NSX CBs are totally selective, as long as the ration between sizes is greater than 1.6 and the ratio between ratings is greater than 2.5. The same rules apply for the total selectivity with the miniature circuit-breakers Multi9 further downstream (see Fig. H55).

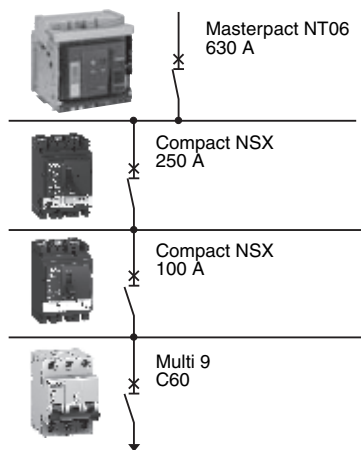

H26

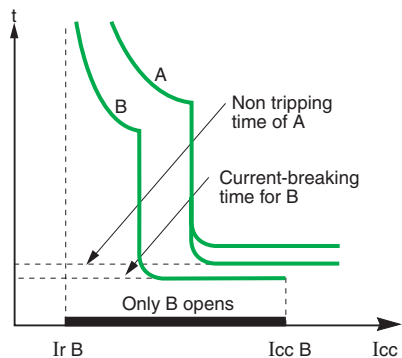

Fig. H55 : 4 level discrimination with Schneider Electric circuit breakers : Masterpact NT Compact NSX and Multi 9

Energy discrimination with current limitation

Cascading between 2 devices is normally achieved by using the tripping of the upstream circuit-breaker A to help the downstream circuit-breaker B to break the current. The discrimination limit I_s is consequently equal to the ultimate breaking current I_{cu} B of circuit-breaker B acting alone, as cascading requires the tripping of both devices.

The energy discrimination technology implemented in Compact NSX circuit-breakers allows to improve the discrimination limit to a value higher than the ultimate breaking current I_{cu} B of the downstream circuit-breaker. The principle is as follows:

- The downstream limiting circuit-breaker B sees a very high short-circuit current. The tripping is very fast (<1 ms) and then, the current is limited
- The upstream circuit-breaker A sees a limited short-circuit current compared to its breaking capability, but this current induces a repulsion of the contacts. As a result, the arcing voltage increases the current limitation. However, the arc energy is not high enough to induce the tripping of the circuit-breaker. So, the circuit-breaker A helps the circuit-breaker B to trip, without tripping itself. The discrimination limit can be higher than I_{cu} B and the discrimination becomes total with a reduced cost of the devices

Natural total discrimination with Compact NSX

The major advantage of the Compact NSX range is to provide a natural total discrimination between two series-connected devices if:

- The ratio of the two trip-unit current ratings is > 1.6
- The ratio of rated currents of the two circuit-breakers is > 2.5

Logic discrimination or “Zone Sequence Interlocking – ZSI”

This type of discrimination can be achieved with circuit-breakers equipped with specially designed electronic trip units (Compact, Masterpact): only the Short Time Protection (STP) and Ground Fault Protection (GFP) functions of the controlled devices are managed by Logic Discrimination. In particular, the Instantaneous Protection function - inherent protection function - is not concerned.

Settings of controlled circuit-breakers

- time delay: there are no rules, but staging (if any) of the time delays of time discrimination must be applied ($\Delta tD1 \geq \Delta tD2 \geq \Delta tD3$),
- thresholds: there are no threshold rules to be applied, but natural staging of the protection device ratings must be complied with ($I_{crD1} \geq I_{crD2} \geq I_{crD3}$).

Note: This technique ensures discrimination even with circuit-breakers of similar ratings.

Principles

Activation of the Logic Discrimination function is via transmission of information on the pilot wire:

- ZSI input:
 - low level (no downstream faults): the Protection function is on standby with a reduced time delay (γ 0,1 s),
 - high level (presence of downstream faults): the relevant Protection function moves to the time delay status set on the device.
- ZSI output:
 - low level: the trip unit detects no faults and sends no orders,
 - high level: the trip unit detects a fault and sends an order.

Operation

A pilot wire connects in cascading form the protection devices of an installation (see Fig. H56). **When a fault occurs, each circuit-breaker** upstream of the fault (detecting a fault) sends an order (high level output) and moves the upstream circuit-breaker to its natural time delay (high level input). The circuitbreaker placed just above the fault does not receive any orders (low level input) and thus trips almost instantaneously.

Discrimination schemes based on logic techniques are possible, using CBs equipped with electronic tripping units designed for the purpose (Compact, Masterpact) and interconnected with pilot wires

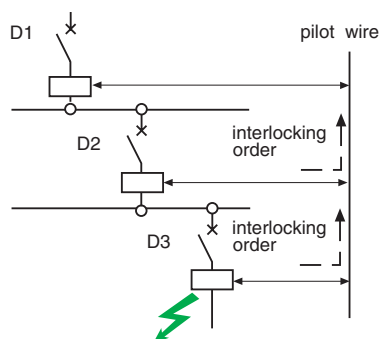

Fig. H56 : Logic discrimination.

Discrimination quality

This technique enables:

- easy achievement as standard of discrimination on 3 levels or more,
- elimination of important stresses on the installation, relating to time-delayed tripping of the protection device, in event of a fault directly on the upstream busbars.

All the protection devices are thus virtually instantaneous,

- easy achievement of downstream discrimination with non-controlled circuit-breakers.

H28

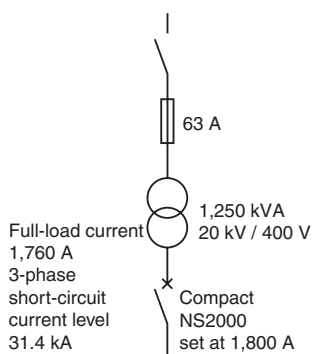

Fig. H57 : Example

4.6 Discrimination MV/LV in a consumer's substation

In general the transformer in a consumer's substation is protected by MV fuses, suitably rated to match the transformer, in accordance with the principles laid down in IEC 60787 and IEC 60420, by following the advice of the fuse manufacturer.

The basic requirement is that a MV fuse will not operate for LV faults occurring downstream of the transformer LV circuit-breaker, so that the tripping characteristic curve of the latter must be to the left of that of the MV fuse pre-arcing curve.

This requirement generally fixes the maximum settings for the LV circuit-breaker protection:

- Maximum short-circuit current-level setting of the magnetic tripping element
- Maximum time-delay allowable for the short-circuit tripping element (see Fig. H57)
- Short-circuit level at MV terminals of transformer: 250 MVA
- Transformer MV/LV: 1,250 kVA 20/0.4 kV
- MV fuses: 63 A
- Cabling, transformer - LV circuit-breaker: 10 metres single-core cables
- LV circuit-breaker: Compact NSX 2000 set at 1,800 A (Ir)

What is the maximum short-circuit trip current setting and its maximum time delay allowable?

The curves of Figure H58 show that discrimination is assured if the short-time delay tripping unit of the CB is set at:

- A level $\leq 6 I_r = 10.8 \text{ kA}$
- A time-delay setting of step 1 or 2

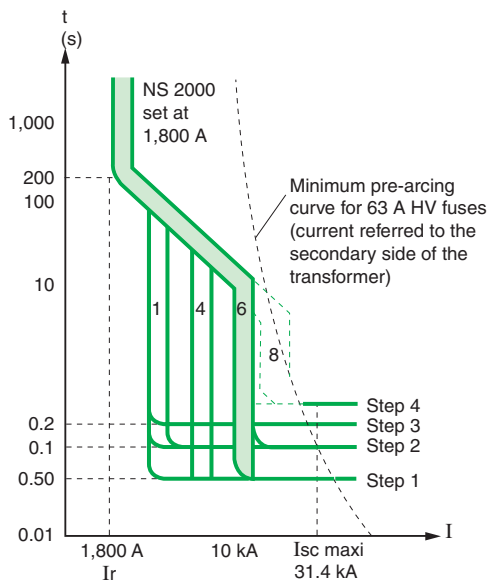

Fig. H58 : Curves of MV fuses and LV circuit-breaker